



***Impact Study for Generation  
Interconnection Request  
GEN – 2004 – 020***

***SPP Coordinated Planning  
(#GEN-2004-020)***

**August 2005**

## Summary

I2R performed the following Study at the request of the Southwest Power Pool (SPP) for Generation Interconnection request Gen-2004-020. The request for interconnection was placed with SPP in accordance SPP's Open Access Transmission Tariff, which covers new generation interconnections on SPP's transmission system.

Pursuant to the tariff, I2R was asked to perform a detailed Impact Study of the generation interconnection request to satisfy the Impact Study Agreement executed by the requesting customer and SPP.

The Federal Energy Regulatory Commission finalized the grid-interconnection rule for large wind power facilities May 25, 2005. The final rule provides that wind generators must meet the following conditions, if the transmission service provider demonstrates they are needed. First, if needed, a large wind generating facility must remain operational during voltage disturbances on the grid. Second, large wind plants must, if needed, meet the same technical criteria for providing reactive power to the grid as required of conventional large generating facilities. Third, the final rule provides for supervisory control and data acquisition (SCADA), if needed, to ensure appropriate real-time communication and data exchanges between the wind power producer and the grid operator.

To this end SPP recommends that the Customer strongly consider these reliability requirements of the wind farm based on the FERC final rule. The study found that during 9 of the 18 faults studied in the summer case and 10 of the 18 studied in the winter case the GE standard protection scheme allowed the wind farm to trip due to low voltage. With the GE Low Voltage Ride Through (LVRT) turbines may be available that would ride through these faults. The use of the GE LVRT with the Four switched capacitor banks, sized at 2.4 MVAR will satisfy the first and second FERC requirement noted above.

*System Impact Study for Generation  
Interconnection Request  
For  
GEN-2004-020*

Prepared by I2R Technologies

August 2005

# System Impact Study GEN-2004-020

## Table of Contents

<b>I. EXECUTIVE SUMMARY.....</b>	<b>1</b>
<b>II. INTRODUCTION .....</b>	<b>2</b>
<b>III. CONFIGURATION.....</b>	<b>4</b>
<b>IV. LOAD FLOW MODELING .....</b>	<b>7</b>
<b>V. DYNAMIC MODELING .....</b>	<b>9</b>
<b>VI. FAULT SCENARIOS .....</b>	<b>9</b>
<b>VII. RESULTS.....</b>	<b>9</b>
<b>VIII.SENSITIVITIES .....</b>	<b>35</b>
<b>IX. COST ESTIMATE.....</b>	<b>9</b>
<b>X. CONCLUSIONS .....</b>	<b>9</b>

# System Impact Study GEN-2004-020

## I. EXECUTIVE SUMMARY

The Customer has requested a generator interconnection study through the Southwest Power Pool Tariff for a 138 kV interconnection of 27 MW to be added to a wind farm in the Weatherford, Oklahoma vicinity. The proposed wind farm will be connected to an existing switching station to be constructed on the Weatherford Junction Station to Clinton Junction 138 kV line. It will be located approximately three miles from the Weatherford Junction tap. The Customer has requested a study using GE 1.5 MW SLE wind turbines. The projected in-service date for the wind farm is December 2005.

Data supplied by the Interconnection Customer was used to build load flow and dynamics models using PTI's PSS/E™ software package. Each of the wind turbines is modeled individually along with its associated step-up transformer. This level of detail allows an accurate evaluation of the VAR requirements to support the wind farm operation.

SPP provided both summer and winter load flow basecases based on the 2004 MMWG series of load flow models. The title of the summer basecase is "2006 SUMMER, FINAL; FOR DYN." The title of the winter basecase is "2006 WINTER, FINAL; FOR DYN." SPP also defined a comprehensive set of fault scenarios (18) to be evaluated in the dynamic analysis.

The following conclusions are reached from the load flow and dynamic analysis performed in this study:

- The system remained stable for all eighteen scenarios simulated using the summer model.
- The system remained stable for all eighteen scenarios simulated using the winter model.

- The wind turbines were tripped by the under voltage relays in nine/ten of the eighteen scenarios using the summer/winter basecase for nearby faults including single-phase faults.
- For most of the under voltage tripping, the voltage dropped below the lowest acceptable level. The timer for this level is extremely short and thus does not allow for faster relaying.
- For at least three of the fault scenarios, the under voltage tripping occurred after reclosing. Faster reopening after reclosure may allow the relays to be reset and keep the wind turbines on-line. Relaying packages of the GE LVRT turbines may be available that would ride through these faults.

## **II. INTRODUCTION**

The Customer has requested a generator interconnection study through the Southwest Power Pool Tariff for a 138 kV interconnection of 27 MW to be added to a wind farm in the Weatherford, Oklahoma vicinity. The proposed wind farm will be connected to an existing switching station to be constructed on the Weatherford Junction Station to Clinton Junction 138 kV line. It will be located approximately three miles from the Weatherford Junction tap. The Customer has requested a study using GE 1.5 MW SLE wind turbines. The projected in-service date for the wind farm is December 2005.

## **III. CONFIGURATION**

The proposed wind farm will be connected to an existing switching station to be constructed on the Weatherford Junction Station to Clinton Junction 138 kV line. It will be located approximately three miles from the Weatherford Junction tap. A 0.5 mile radial 138 kV transmission line will connect the wind farm to the new switching station. Figure 1 is a representation of the electrical grid in the area and the Customer's Wind farm.

FIGURE 1

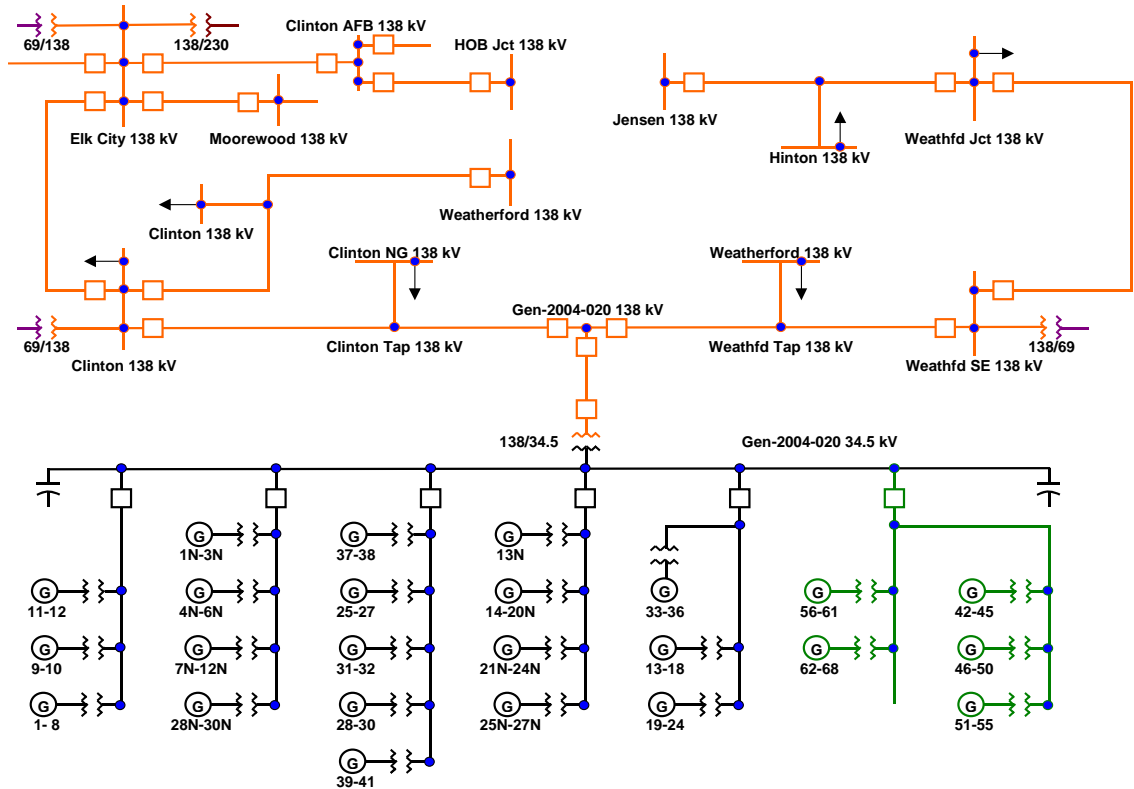

The Interconnection Customer substation will contain a 138/34.5 kV transformer connected to the 138 kV bus via a dedicated breaker. Test data for a 96/128/160 MVA rated transformer with 9.41 percent impedance and load loss of 192,781 watts at the 138/34.5 kV tap setting was provided.

The 138/34.5 kV transformer will also be connected to a 34.5 kV bus which will serve six 34.5 kV feeders each with a dedicated breaker. Four switched capacitor banks, sized at 2.4 MVAR, will be connected directly to the 34.5 kV bus via Feeder positions 1 and 8 as shown on the substation one-line diagram.

Each of the wind turbines is connected to one of the 34.5 kV feeders via its own step-up transformer. A 1.75 MVA rated 34.5/0.575 kV transformer with a

resistance of 0.77 percent and an inductance of 5.79 percent was used with the GE machines.

The Interconnection Customer provided detailed feeder information including conductor type, resistance, inductance, capacitance and length for each configuration. These values were converted to per unit values using a voltage of 34.5 kV and a 100 MVA base.

Over/under voltage and frequency relays will monitor the 34.5 kV bus and have the capability to open each the 34.5 kV feeder breakers independently.

#### **IV. LOAD FLOW MODELING**

SPP provided both summer and winter loadflow basecases based on the 2004 MMWG series of loadflow models. The title of the summer basecase is “2006 SUMMER, FINAL; FOR DYN.” The title of the winter basecase is “2006 WINTER, FINAL; FOR DYN.” These models provided the starting point for building a load flow model to evaluate the proposed wind farm. Shaw Group PTI’s PSS/E™ load flow program was used for this analysis

Prior project Gen-2001-026 is connected to the Washita as bus 56103 in the basecase models. Its generation output was ramped to its maximum value of 74.25 MW. Other generators in the SPP footprint were ramped down to compensate for the increased generation.

Prior queued project Gen-2003-004 was added to the basecase at bus 56103. Its generation output was ramped to its maximum value of 100.0 MW. This generation was dispatched into the AEP West control area.

For both project Gen-2003-022 and Gen-2004-020, each individual wind turbine was modeled along with its step-up transformer. This required the



addition of several new buses for the turbines, step-up transformers, line segments, and substation. New generator, transformer, capacitor bank, and line segment models were added to the existing load flow models to provide a detailed representation of the wind farm.

The GE wind turbines are rated at 1.667 MVA. For dispatch purposes, the nominal output of each turbine is 1.5 MW at unity power factor. A Shaw Group PTI PSS/E™ IPLAN program was used to build the load flow models for the GE machines. This program set the reactive requirements to zero thus representing a fixed unity power factor.

Gen-2003-022 generation output was ramped to its maximum value of 120.0 MW. 106.5 MW of this generation was dispatched into the AEP West control area. Other generators in the SPP footprint were ramped down to compensate for the remaining 13.5 MW of generation.

Gen-2003-020 generation output was ramped to its maximum value of 27.0 MW. Other generators in the SPP footprint were ramped down to compensate for the increased generation.

In the summer loadflow model with the new wind farm in service, none of the switched capacitor banks were required to be in service; however, in the winter loadflow model, one bank was switched into service. The banks were automatically switched in or out to maintain a 1.0 per unit voltage.

## **V. DYNAMIC MODELING**

A Shaw Group PTI PSS/E™ IPLAN program was used to build the dynamic models for the GE machines. This program built user models to represent the dynamic response of wind turbines. It also built over/under voltage

relay and over/under frequency relay models. These models were used without modification. They included the DFIGPQ, CGECN2, TWIND1, TSHAFT, GEAERO, TGPTCH, VTGTRP, and FRQTRP user models.

The VTGTRP model represented the under/over voltage relay actions for the GE machines in this analysis. For comparison the voltage thresholds, relay times and breaker times for the GE machines are provided below:

- Lower Voltage Threshold            0.300 P.U.
- Upper Voltage Threshold            5.000 P.U.
- Relay Pickup Time (delay)        0.020 Seconds
- Breaker Time                            0.150 Seconds
  
- Lower Voltage Threshold            0.700 P.U.
- Upper Voltage Threshold            5.000 P.U.
- Relay Pickup Time (delay)        0.100 Seconds
- Breaker Time                            0.150 Seconds
  
- Lower Voltage Threshold            0.750 P.U.
- Upper Voltage Threshold            5.000 P.U.
- Relay Pickup Time (delay)        1.000 Seconds
- Breaker Time                            0.150 Seconds
  
- Lower Voltage Threshold            0.850 P.U.
- Upper Voltage Threshold            5.000 P.U.
- Relay Pickup Time (delay)        10.00 Seconds
- Breaker Time                            0.150 Seconds
  
- Lower Voltage Threshold            0.000 P.U.
- Upper Voltage Threshold            1.100 P.U.
- Relay Pickup Time (delay)        1.000 Seconds
- Breaker Time                            0.150 Seconds
  
- Lower Voltage Threshold            0.000 P.U.

- Upper Voltage Threshold            1.150 P.U.
- Relay Pickup Time (delay)        0.100 Seconds
- Breaker Time                        0.150 Seconds
  
- Lower Voltage Threshold          0.000 P.U.
- Upper Voltage Threshold          1.300 P.U.
- Relay Pickup Time (delay)        0.020 Seconds
- Breaker Time                        0.150 Seconds

The FRQTRP model represented the under/over frequency relay actions for the GE machines in this analysis. For comparison the frequency thresholds, relay times and breaker times for the GE machines are provided below:

- Lower Frequency Threshold        56.5 P.U.
- Upper Frequency Threshold        66.0 P.U.
- Relay Pickup Time (delay)        0.02 Seconds
- Breaker Time                        0.15 Seconds
  
- Lower Frequency Threshold        57.5 P.U.
- Upper Frequency Threshold        66.0 P.U.
- Relay Pickup Time (delay)        10.00 Seconds
- Breaker Time                        0.15 Seconds
  
- Lower Frequency Threshold        54.0 P.U.
- Upper Frequency Threshold        61.5 P.U.
- Relay Pickup Time (delay)        30.00 Seconds
- Breaker Time                        0.15 Seconds
- Lower Frequency Threshold        54.0 P.U.
- Upper Frequency Threshold        62.5 P.U.
- Relay Pickup Time (delay)        0.02 Seconds
- Breaker Time                        0.15 Seconds

## **VI. FAULT SCENARIOS**

The SPP defined the following 18 fault scenarios.

1. A three-phase fault on the Weatherford Junction to Hinton to Jensen Road 138 kV line at Weatherford Junction was evaluated. The fault was applied at Weatherford Junction for 3.5 cycles. Removing the 138 kV line between the Weatherford Junction Substation and the Jensen Substation temporarily cleared the fault. After 6 cycles, 120 cycles, and 180 cycles the 138 kV line was reclosed and the fault was reapplied at Weatherford Junction for 24 cycles. Removing the 138 kV line between the Weatherford Junction Substation and the Jensen Substation cleared the fault after each reclosing as shown in Figure 2.

**FIGURE 2**

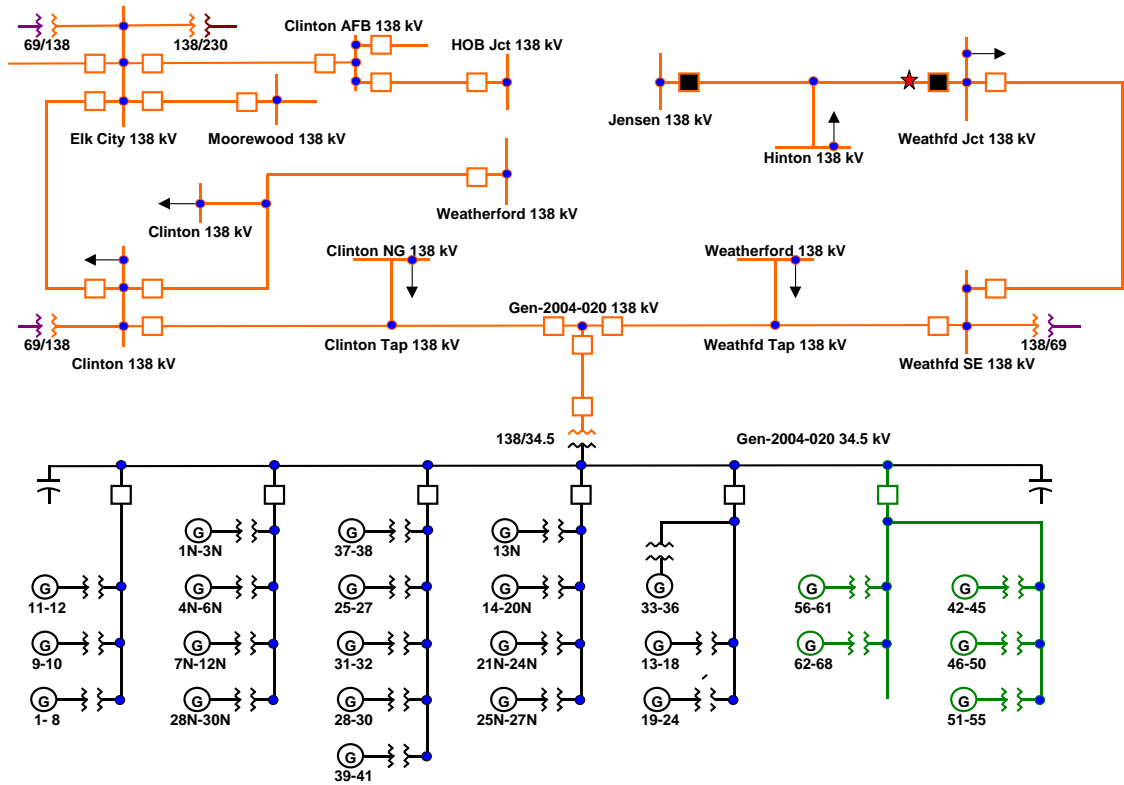

2. A single-phase fault on the Weatherford Junction to Hinton to Jensen Road 138 kV line at Weatherford Junction was evaluated. The fault was applied at Weatherford Junction for 3.5 cycles. Removing the 138 kV line between the Weatherford Junction Substation and the Jensen Substation temporarily cleared the fault.

the fault. After 6 cycles, 120 cycles, and 180 cycles the 138 kV line was reclosed and the fault was reapplied at Weatherford Junction for 24 cycles. Removing the 138 kV line between the Weatherford Junction Substation and the Jensen Substation cleared the fault after each reclosing as shown in Figure 2.

3. A three-phase fault on the Weatherford Junction to Weatherford SE 138 kV line at Weatherford Junction was evaluated. The fault was applied at Weatherford Junction for 3.5 cycles. Removing the 138 kV line between the Weatherford Junction Substation and the Weatherford SE Substation temporarily cleared the fault. After 6 cycles, 120 cycles, and 180 cycles the 138 kV line was reclosed and the fault was reapplied at Weatherford Junction for 24 cycles. Removing the 138 kV line between the Weatherford Junction Substation and the Weatherford Substation cleared the fault after each reclosing as shown in Figure 3.
  
4. A single-phase fault on the Weatherford Junction to Weatherford SE 138 kV line at Weatherford Junction was evaluated. The fault was applied at Weatherford Junction for 3.5 cycles. Removing the 138 kV line between the Weatherford Junction Substation and the Weatherford SE Substation temporarily cleared the fault. After 6 cycles, 120 cycles, and 180 cycles the 138 kV line was reclosed and the fault was reapplied at Weatherford Junction for 24 cycles. Removing the 138 kV line between the Weatherford Junction Substation and the Weatherford Substation cleared the fault after each reclosing as shown in Figure 3.

**FIGURE 3**

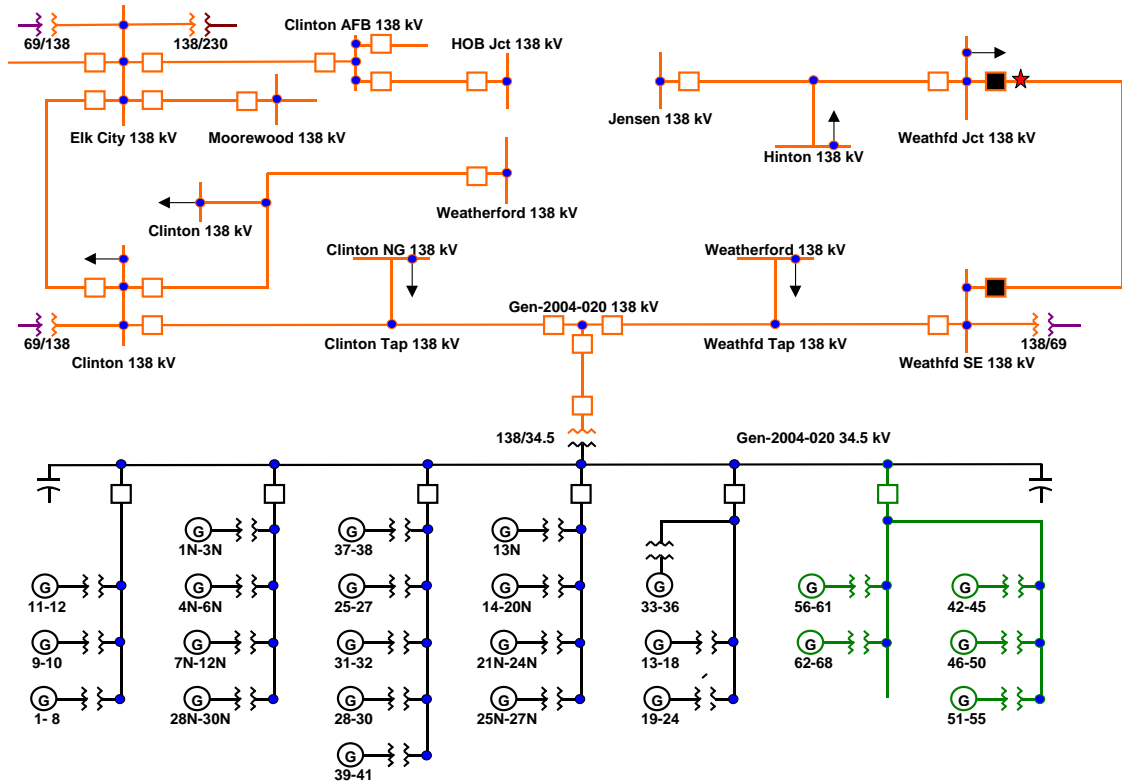

5. A three-phase fault on the Weatherford SE to Weatherford Tap to Gen-2003-022 138 kV line at Weatherford SE was evaluated. The fault was applied at Weatherford SE for 3.5 cycles. Removing the 138 kV line between the Weatherford SE Substation and the Gen-2003-022 Switching Station temporarily cleared the fault. After 30 cycles the 138 kV line was reclosed and the fault was reapplied at Weatherford SE for 15 cycles. Removing the 138 kV line between the Weatherford SE Substation and the Gen-2003-022 Switching Station cleared the fault after reclosing as shown in Figure 4.

6. A single-phase fault on the Weatherford SE to Weatherford Tap to Gen-2003-022 138 kV line at Weatherford SE was evaluated. The fault was applied at Weatherford SE for 3.5 cycles. Removing the 138 kV line between the Weatherford SE Substation and the Gen-2003-022 Switching Station temporarily cleared the fault. After 30 cycles the 138 kV line was reclosed and the fault was reapplied at Weatherford SE for 15 cycles. Removing the

138 kV line between the Weatherford SE Substation and the Gen-2003-022 Switching Station cleared the fault after reclosing as shown in Figure 4.

**FIGURE 4**

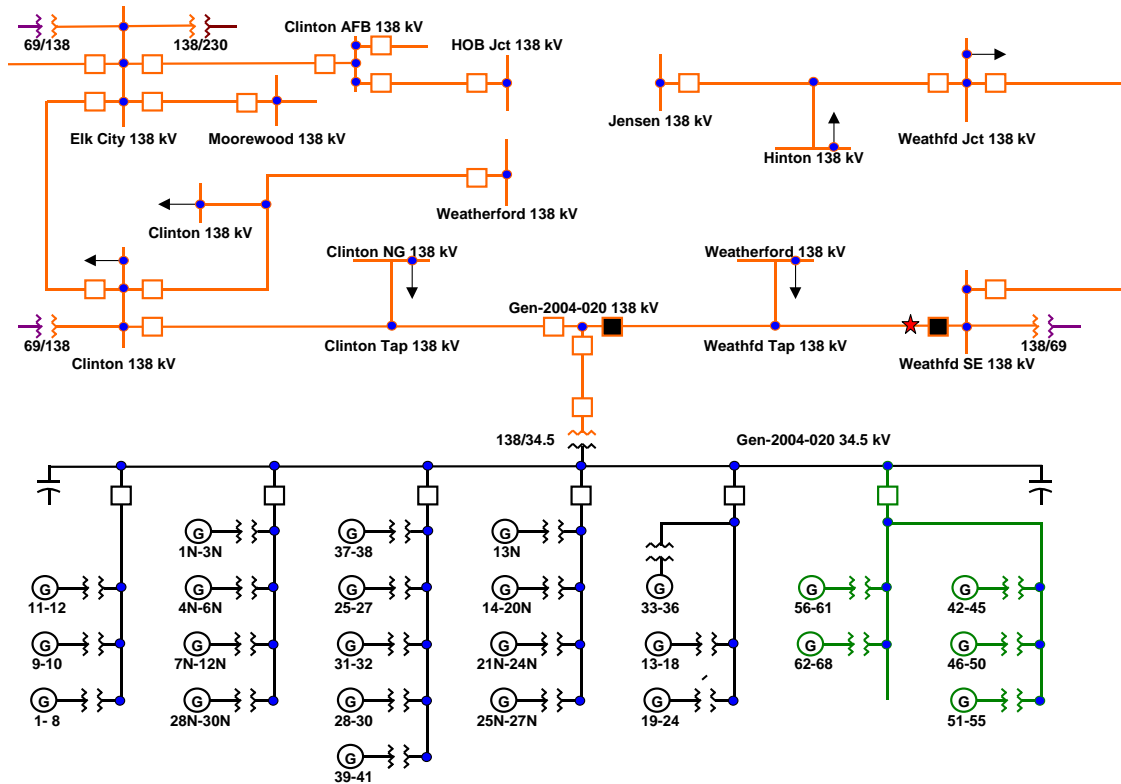

7. A three-phase fault on the Clinton Junction to Clinton Tap to Gen-2003-022 138 kV line at Clinton Junction was evaluated. The fault was applied at Clinton Junction for 3.5 cycles. Removing the 138 kV line between the Clinton Junction Substation and the Gen-2003-022 Switching Station temporarily cleared the fault. After 30 cycles the 138 kV line was reclosed and the fault was reapplied at Clinton Junction for 15 cycles. Removing the 138 kV line between the Clinton Junction Substation and the Gen-2003-022 Switching Station cleared the fault after reclosing as shown in Figure 5.

8. A single-phase fault on the Clinton Junction to Clinton Tap to Gen-2003-022 138 kV line at Clinton Junction was evaluated. The fault was applied at

Clinton Junction for 3.5 cycles. Removing the 138 kV line between the Clinton Junction Substation and the Gen-2003-022 Switching Station temporarily cleared the fault. After 30 cycles the 138 kV line was reclosed and the fault was reapplied at Clinton Junction for 15 cycles. Removing the 138 kV line between the Clinton Junction Substation and the Gen-2003-022 Switching Station cleared the fault after reclosing as shown in Figure 5.

**FIGURE 5**

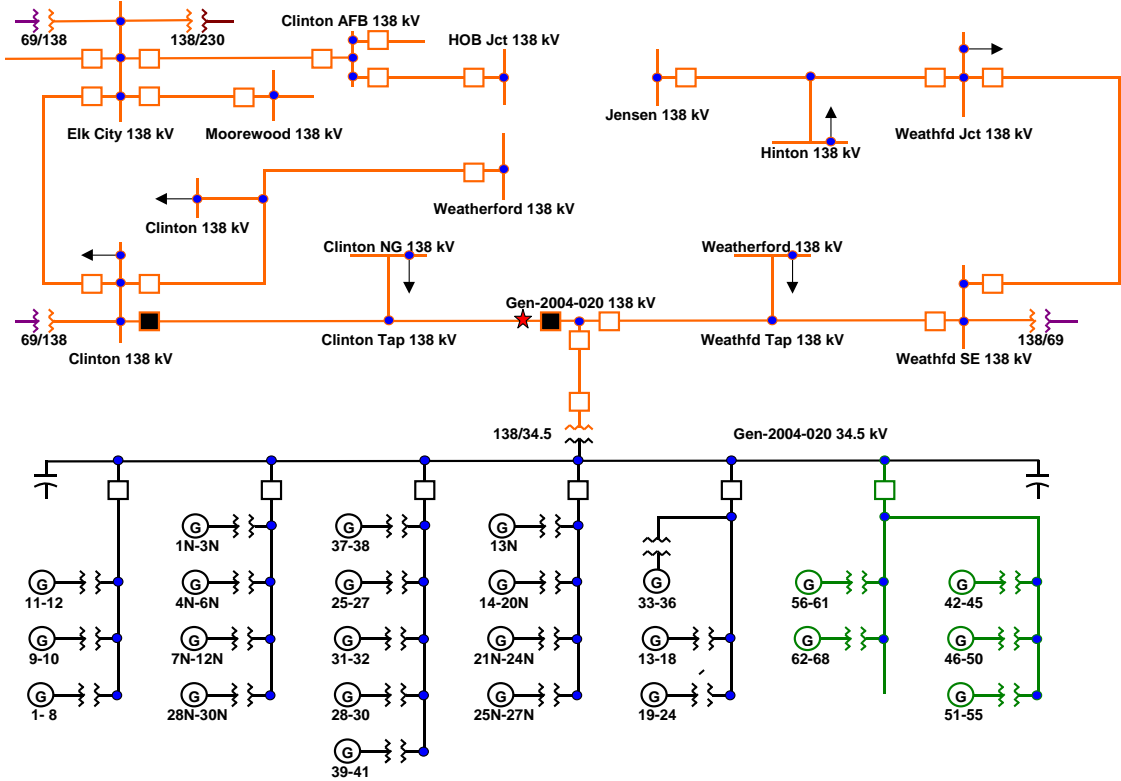

9. A three-phase fault on the Clinton Junction to Clinton to Weatherford 138 kV line at Clinton Junction was evaluated. The fault was applied at Clinton Junction for 3.5 cycles. Removing the 138 kV line between the Clinton Junction Substation and the Weatherford Substation temporarily cleared the fault. After 6 cycles, 120 cycles, and 180 cycles the 138 kV line was reclosed and the fault was reapplied at Clinton Junction for 15 cycles. Removing the 138 kV line between the Clinton Junction Substation and the Weatherford Substation cleared the fault after each reclosing as shown in Figure 6.



10. A single-phase fault on the Clinton Junction to Clinton to Weatherford 138 kV line at Clinton Junction was evaluated. The fault was applied at Clinton Junction for 3.5 cycles. Removing the 138 kV line between the Clinton Junction Substation and the Weatherford Substation temporarily cleared the fault. After 6 cycles, 120 cycles, and 180 cycles the 138 kV line was reclosed and the fault was reapplied at Clinton Junction for 15 cycles. Removing the 138 kV line between the Clinton Junction Substation and the Weatherford Substation cleared the fault after each reclosing as shown in Figure 6.

**FIGURE 6**

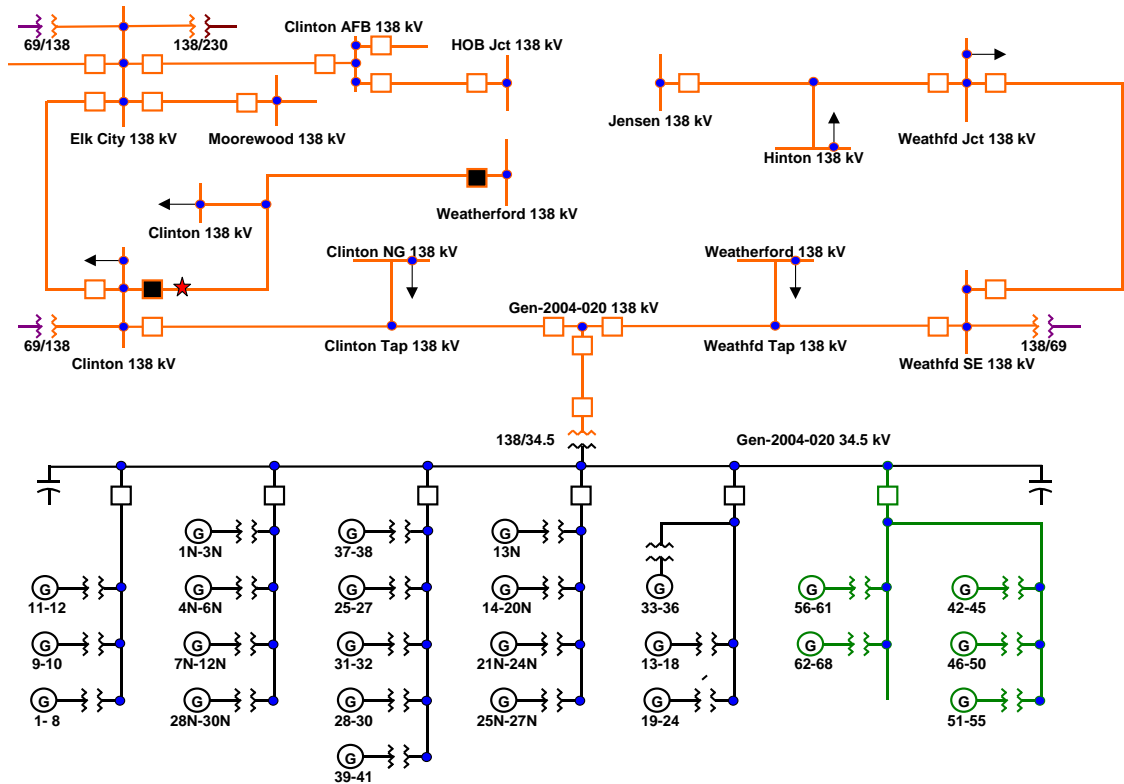

11. A three-phase fault on the Clinton Junction to Elk City 138 kV line at Clinton Junction was evaluated. The fault was applied at Clinton Junction for 3.5 cycles. Removing the 138 kV line between the Clinton Junction Substation and the Elk City Substation temporarily cleared the fault. After 6 cycles, 120 cycles, and 180 cycles the 138 kV line was reclosed and the fault was reapplied at Clinton Junction for 15 cycles. Removing the 138 kV line

between the Clinton Junction Substation and the Elk City Substation cleared the fault after each reclosing as shown in Figure 7.

12. A single-phase fault on the Clinton Junction to Elk City 138 kV line at Clinton Junction was evaluated. The fault was applied at Clinton Junction for 3.5 cycles. Removing the 138 kV line between the Clinton Junction Substation and the Elk City Substation temporarily cleared the fault. After 6 cycles, 120 cycles, and 180 cycles the 138 kV line was reclosed and the fault was reapplied at Clinton Junction for 15 cycles. Removing the 138 kV line between the Clinton Junction Substation and the Elk City Substation cleared the fault after each reclosing as shown in Figure 7.

**FIGURE 7**

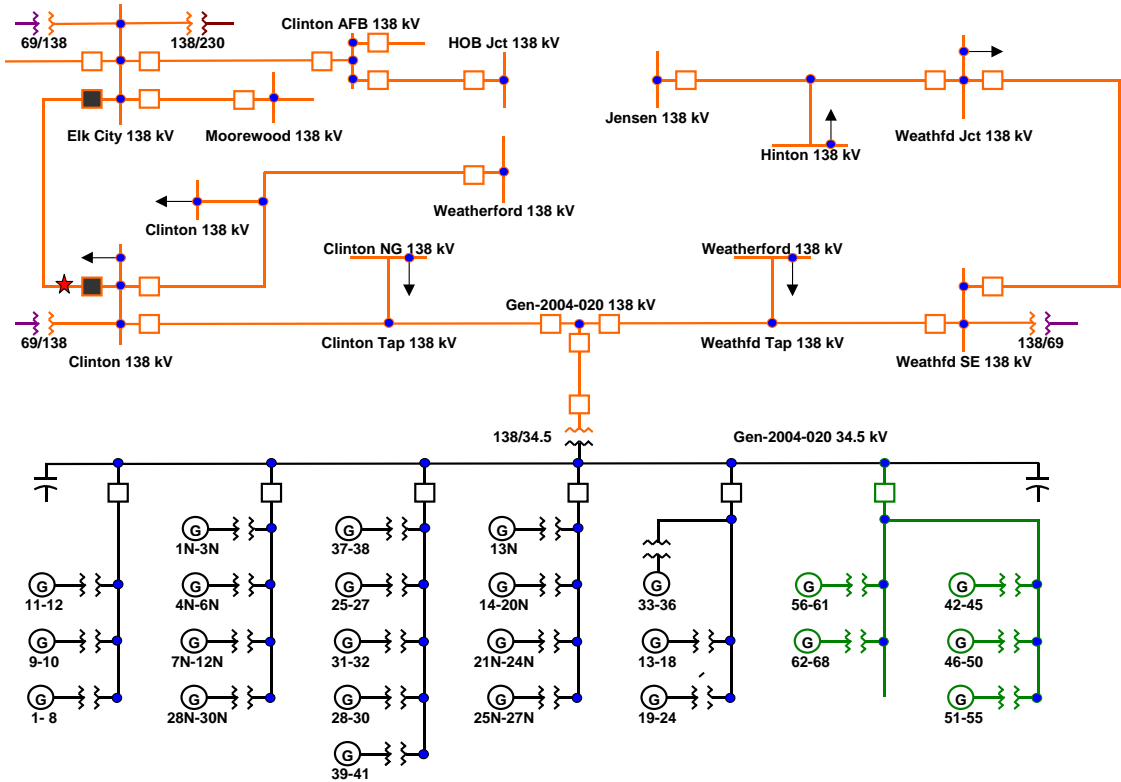

13. A three-phase fault on the Elk City to Moorewood SW 138 kV line at Elk City was evaluated. The fault was applied at Elk City for 5.5 cycles. Removing the 138 kV line between the Elk City Substation and the Moorewood Substation temporarily cleared the fault. After 30 cycles and 120 cycles the 138 kV line was reclosed and the fault was reapplied at Elk City for 15 cycles. Removing the 138 kV line between the Elk City Substation and the Moorewood Substation cleared the fault after each reclosing as shown in Figure 8.

14. A single-phase fault on the Elk City to Moorewood SW 138 kV line at Elk City was evaluated. The fault was applied at Elk City for 5.5 cycles. Removing the 138 kV line between the Elk City Substation and the Moorewood Substation temporarily cleared the fault. After 30 cycles and 120 cycles the 138 kV line was reclosed and the fault was reapplied at Elk City for 15 cycles. Removing the 138 kV line between the Elk City Substation and the Moorewood Substation cleared the fault after each reclosing as shown in Figure 8.

**FIGURE 8**

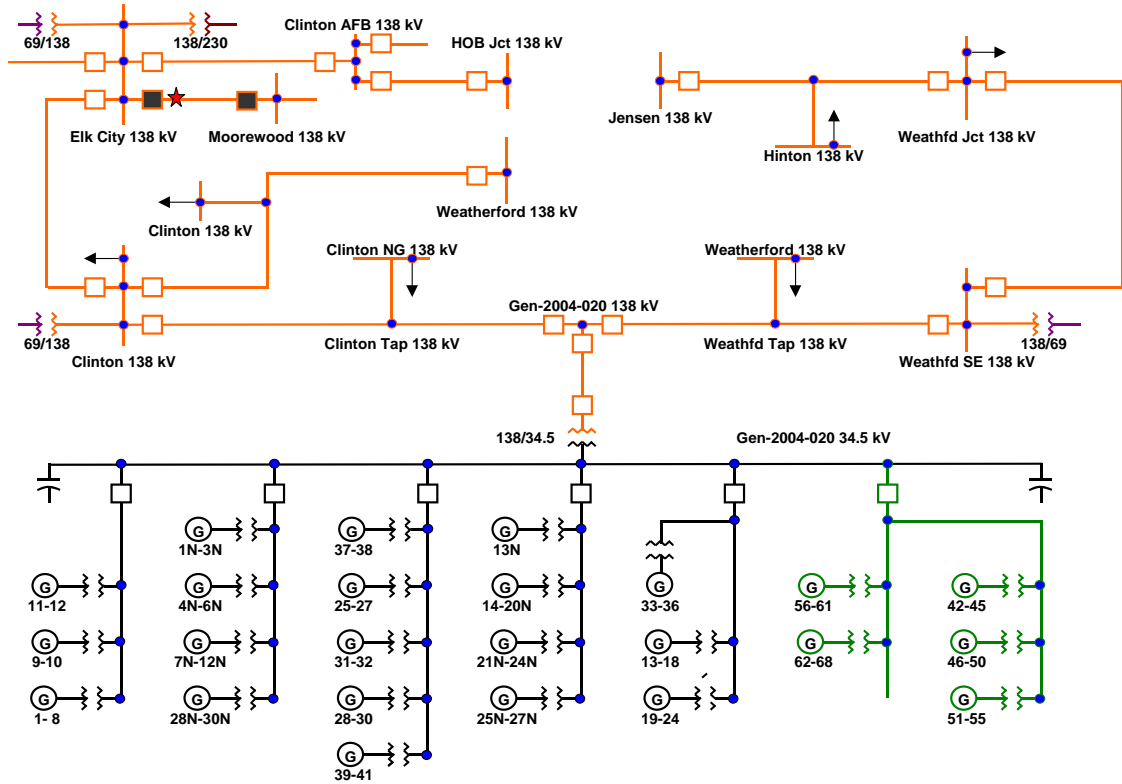

15. A three-phase fault on the Elk City to Clinton Air Force Base 138 kV line at Clinton Air Force Base was evaluated. The fault was applied at Clinton Air Force Base for 5.5 cycles. Removing the 138 kV line between the Elk City Substation and the Clinton Air Force Base Substation temporarily cleared the fault. After 30 cycles and 120 cycles, the 138 kV line was reclosed and the fault was reapplied at Clinton Air Force Base for 15 cycles. Removing the 138 kV line between the Elk City Substation and the Clinton Air Force Base Substation cleared the fault after each reclosing as shown in Figure 9.

FIGURE 9

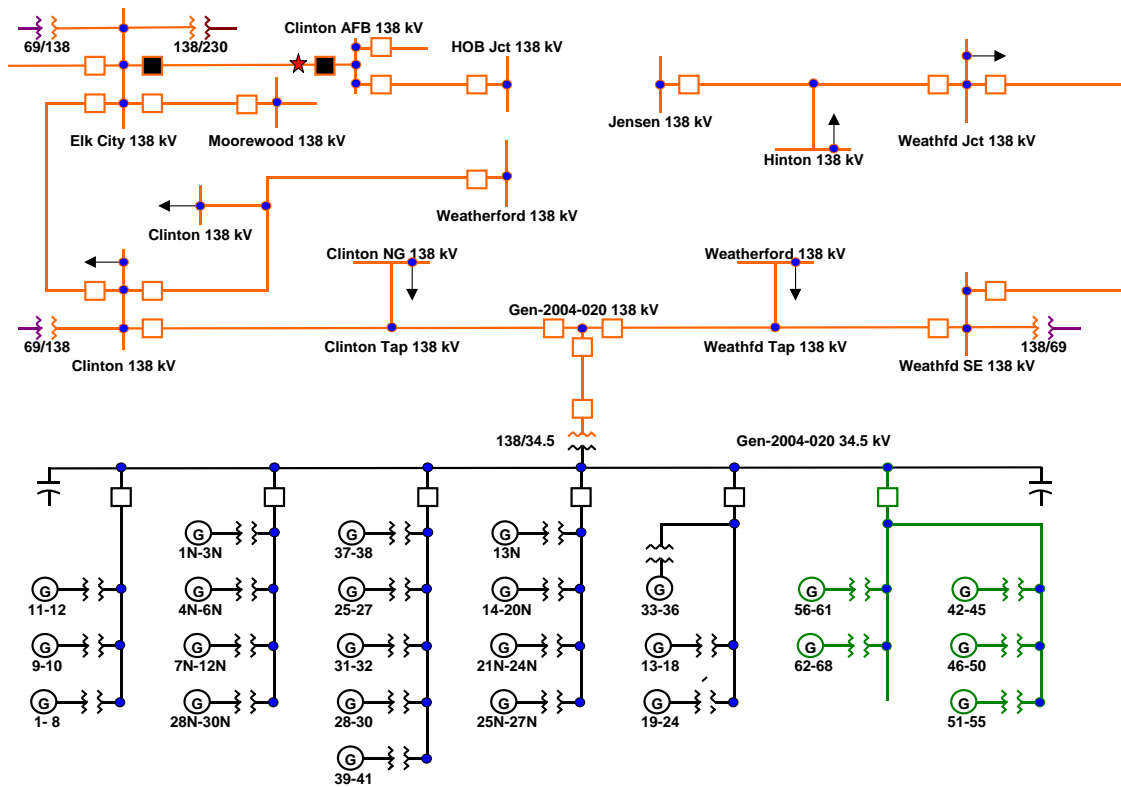

16. A single-phase fault on the Elk City to Clinton Air Force Base 138 kV line at Clinton Air Force Base was evaluated. The fault was applied at Clinton Air Force Base for 5.5 cycles. Removing the 138 kV line between the Elk City Substation and the Clinton Air Force Base Substation temporarily cleared the fault. After 30 cycles and 120 cycles, the 138 kV line was reclosed and the fault was reapplied at Clinton Air Force Base for 15 cycles. Removing the 138 kV line between the Elk City Substation and the Clinton Air Force Base Substation cleared the fault after each reclosing as shown in Figure 9.

17. A three-phase fault on the Clinton Air Force Base to Holbart Junction 138 kV line at Holbart Junction was evaluated. The fault was applied at Holbart Junction for 5.5 cycles. Removing the 138 kV line between the Clinton Air Force Base Substation and the Holbart Junction Substation temporarily

cleared the fault. After 30 cycles and 120 cycles the 138 kV line was reclosed and the fault was reapplied at Holbart Junction for 15 cycles. Removing the 138 kV line between the Clinton Air Force Base Substation and the Holbart Junction Substation cleared the fault after each reclosing as shown in Figure 10.

**FIGURE 10**

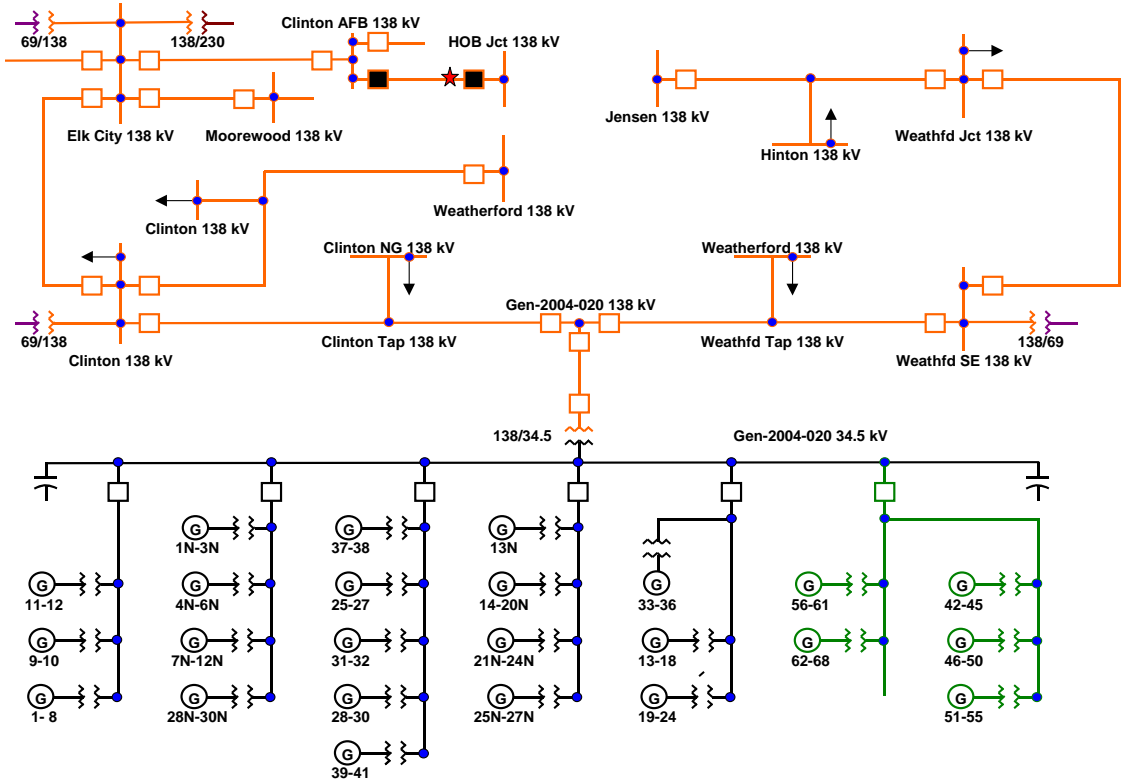

18. A single-phase fault on the Clinton Air Force Base to Holbart Junction 138 kV line at Holbart Junction was evaluated. The fault was applied at Holbart Junction for 5.5 cycles. Removing the 138 kV line between the Clinton Air Force Base Substation and the Holbart Junction Substation temporarily cleared the fault. After 30 cycles and 120 cycles, the 138 kV line was reclosed and the fault was reapplied at Holbart Junction for 15 cycles. Removing the 138 kV line between the Clinton Air Force Base Substation and the Holbart Junction Substation cleared the fault after each reclosing as shown in Figure 10.

## VII. RESULTS

The results of the dynamic simulations for the summer case are shown below in Table 4 and discussed in the following paragraphs.

**TABLE 4**

Scenario	Angle		Speed		Relay		Comments
	Initial	Final	Initial	Final	Tripped	Stable	
1	64.8	73.7	0.200	(1.000)	Yes	Yes	Voltage < 0.3
2	64.8	100.3	0.200	(1.000)	Yes	Yes	Voltage < 0.7
3	64.8	73.6	0.200	(1.000)	Yes	Yes	Voltage < 0.3
4	64.8	137.7	0.200	0.200		Yes	
5	64.8	73.5	0.200	(1.000)	Yes	Yes	Voltage < 0.3
6	64.8	116.4	0.200	0.200		Yes	
7	64.8	74.7	0.200	(1.000)	Yes	Yes	Voltage < 0.3
8	64.8	108.8	0.200	0.200		Yes	
9	64.8	74.8	0.200	(1.000)	Yes	Yes	Voltage < 0.3
10	64.8	84.4	0.200	(1.000)	Yes	Yes	Voltage < 0.7
11	64.8	74.6	0.200	(1.000)	Yes	Yes	Voltage < 0.3
12	64.8	134.6	0.200	0.200		Yes	
13	64.8	164.0	0.200	(1.000)	Yes	Yes	Voltage < 0.7
14	64.8	65.9	0.200	0.200		Yes	
15	64.8	177.6	0.200	0.200		Yes	
16	64.8	65.6	0.200	0.200		Yes	
17	64.8	68.8	0.200	0.200		Yes	
18	64.8	65.4	0.200	0.200		Yes	

Table 4 illustrates that the voltage relays tripped the wind turbines in Scenarios 1, 2, 3, 5, 7, 9, 10, 11 and 13. For the remaining nine scenarios, the wind turbines rode through the fault and remained on-line. For induction machines, stability is best measured by the speed deviations (i.e., whether the machine continues to accelerate or stalls.) In the scenarios where the wind turbines units remain on-line, they remained stable as indicated by the final speed which settled close to the initial value once the fault was cleared and the transients subsided.

Figure 11 below shows the angle swings of several machines in the area for Scenario 1. Scenario 1 simulated a three-phase fault with three re-closings.

The swings for the multiple reclosures can clearly be seen. System stability is maintained as indicated by the damping of the angle swings.

**FIGURE 11**

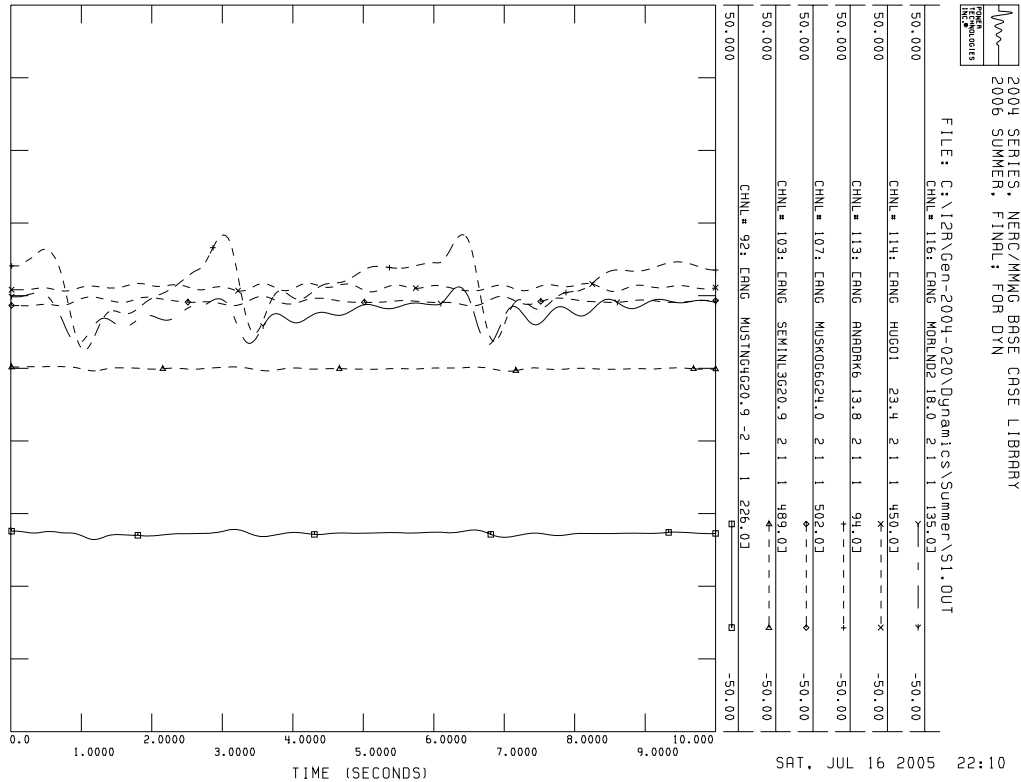

Figure 12 below shows the electrical output from six selected generators from the Gen-2004-020 project for Scenario 1. Figure 12 demonstrates that the generators are tripped off-line as the electrical output goes to zero. The sequence of events for this scenario is as follows:

- Time = 0.100 Fault is applied
- Time = 0.108 Voltage drops below 0.3 and relay timer is set
- Time = 0.129 Breaker time is set after 0.02 second delay
- Time = 0.279 Wind generators are tripped after 0.15 breaker time

The sequence of events is similar for Scenarios 1, 3, 5, 7, 9 and 11. The voltage drops below the lowest setting of the voltage relays and starts the timer, which



expires after 0.02 seconds (1.2 cycles). It is presently impossible to clear the fault faster than 1.2 cycles.

**FIGURE 12**

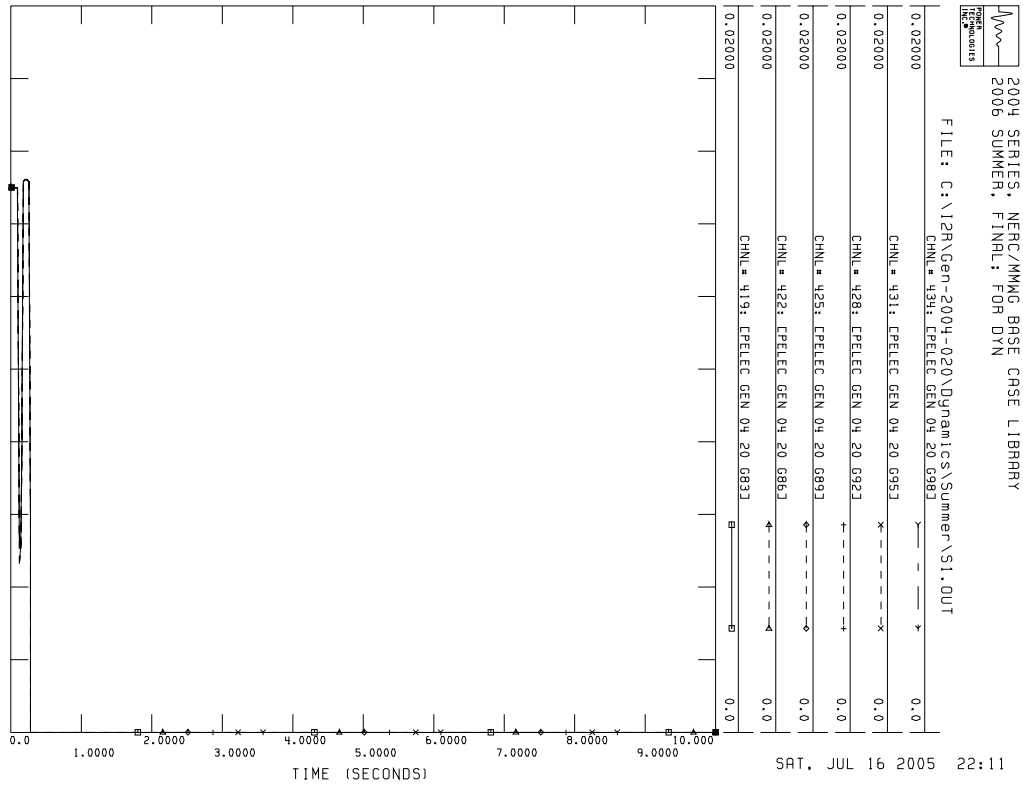

Figure 13 below shows the angle swings of several machines in the area for Scenario 2. Scenario 2 simulated a single-phase fault with three re-closings. The swings for the multiple reclosures can clearly be seen. System stability is maintained as indicated by the damping of the angle swings. It can be seen by comparing Figures 11 and 13 that the single-phase faults produce smaller angular swings than the three-phase faults.

**FIGURE 13**

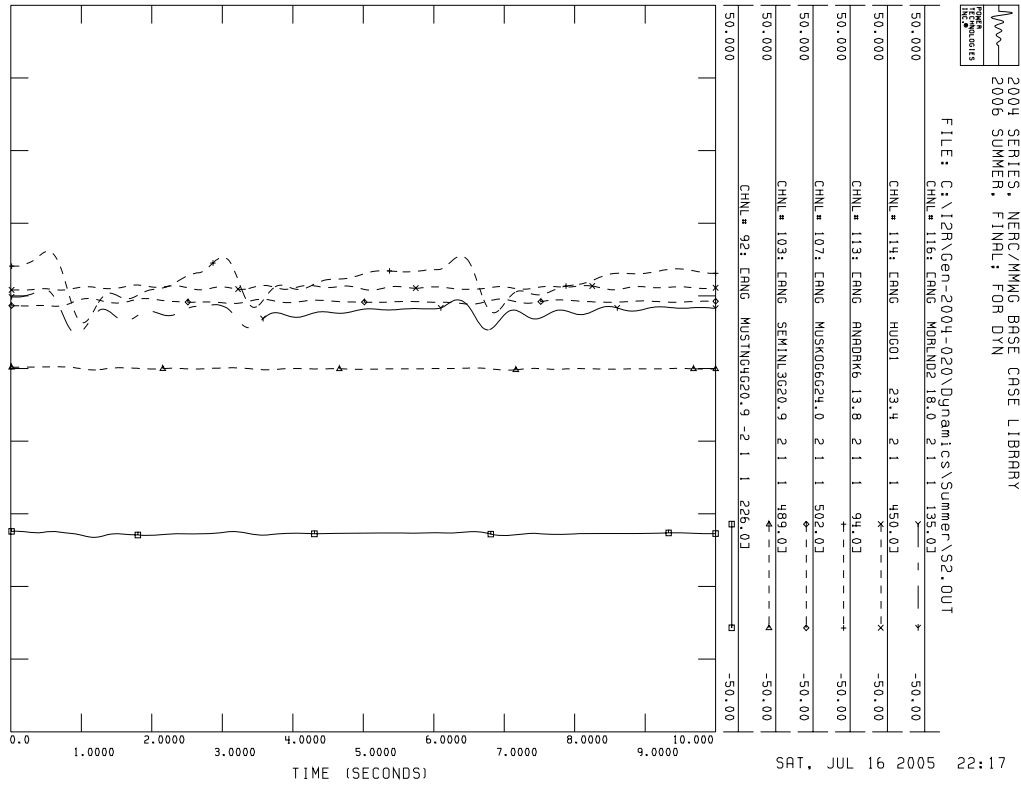

Figure 14 below shows the electrical output from six selected generators from the Gen-2004-020 project for Scenario 2. Figure 14 demonstrates that the generators are tripped off-line as the electrical output goes to zero. The sequence of events for this scenario is as follows:

- Time = 0.100 Fault is applied
- Time = 0.113 Voltage drops below 0.7 and relay timer is set
- Time = 0.133 Voltage rises above 0.7 and relay timer is reset
- Time = 0.158 Fault Removed
- Time = 0.258 Fault is re-applied
- Time = 0.263 Voltage drops below 0.7 and relay timer is set
- Time = 0.363 Breaker time is set after 0.1 second delay
- Time = 0.513 Wind generators are tripped after 0.15 breaker time

The sequence of events is similar for Scenarios 2, 10 and 13. The voltage drops below the next lowest setting of the voltage relays but is reset before the timer expires. On reclosure, the voltage drops below the lowest setting of the voltage relays and starts the timer, which expires after 0.1 seconds (6 cycles). The fault was applied for 24 cycles before reopening. Reduction in this time to a value below 6 cycles may allow the wind turbines to remain on-line.

**FIGURE 14**

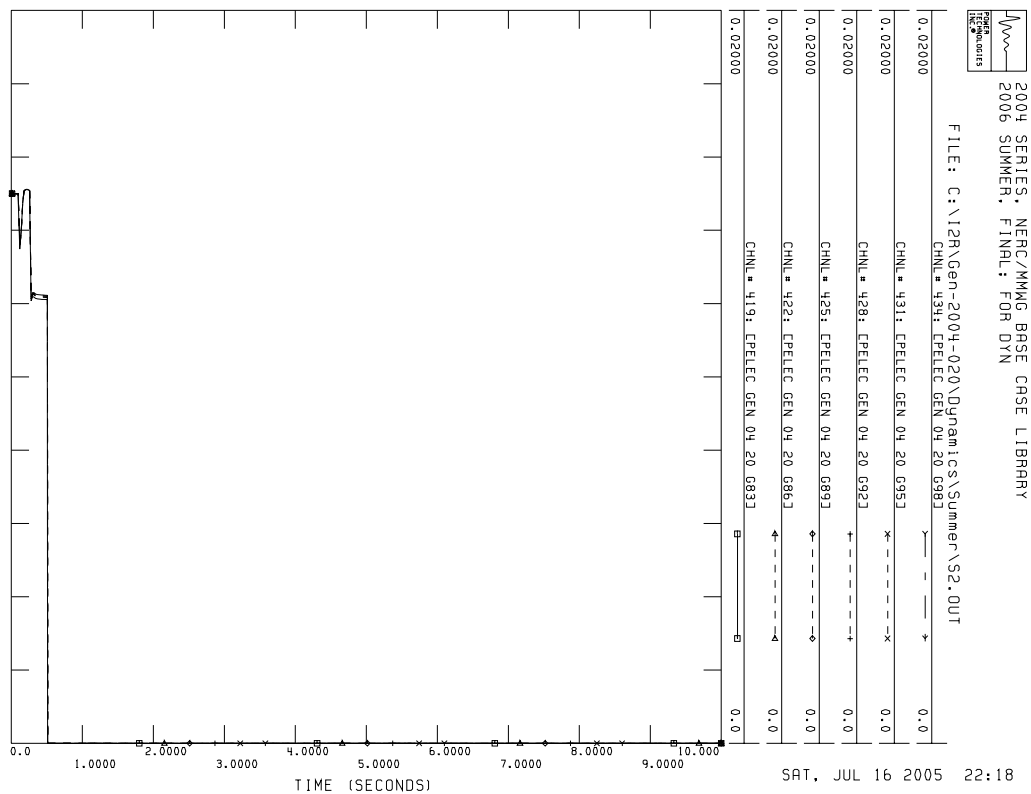

Figure 15 below shows the angle swings of several machines in the area for Scenario 15. Scenario 15 simulated a three-phase fault with two re-closings. The swings for the multiple reclosures can clearly be seen. System stability is maintained as indicated by the damping of the angle swings.

FIGURE 15

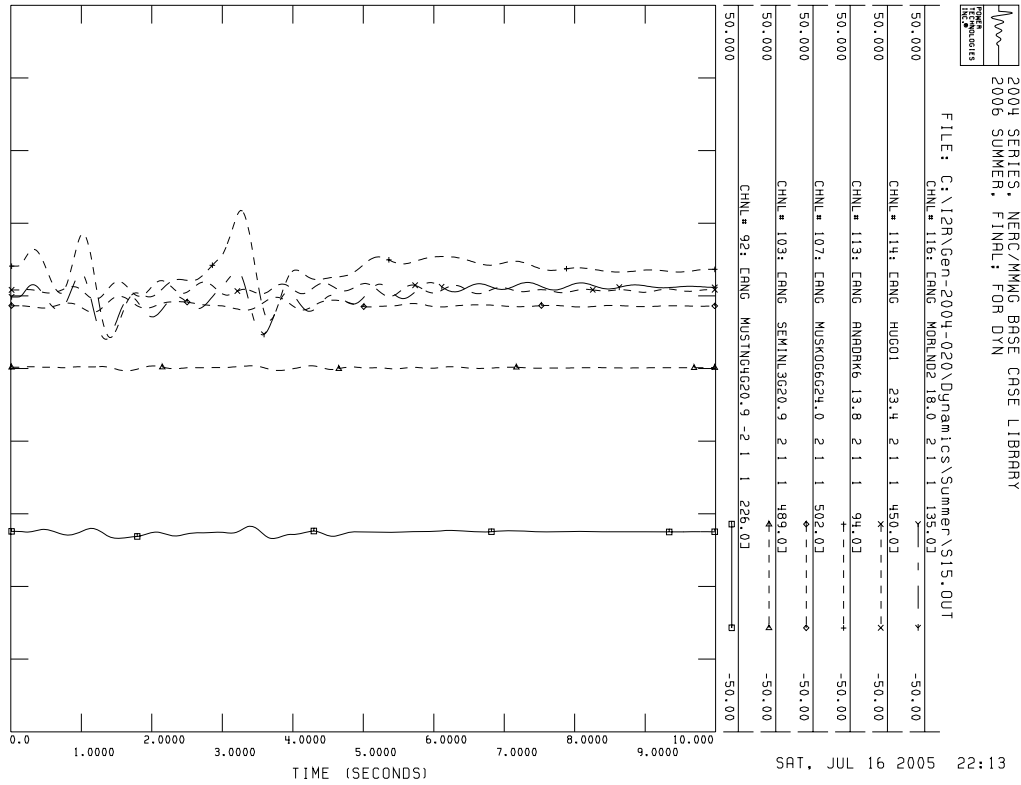
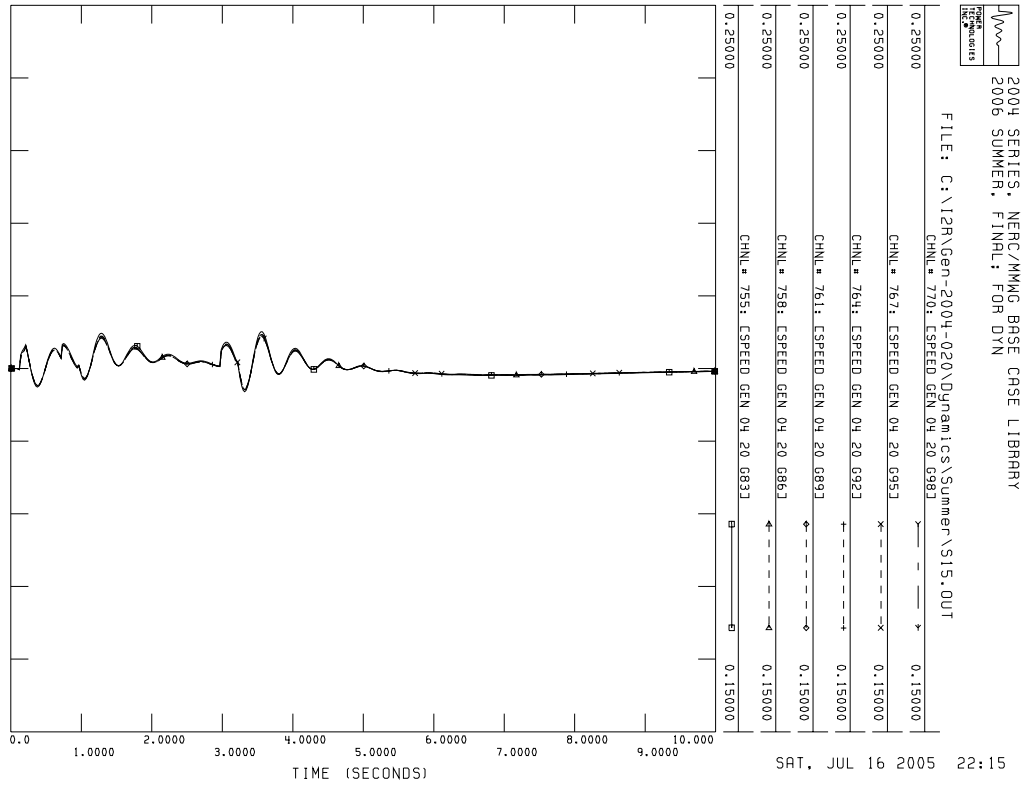

Figure 16 below shows the turbine speed from six selected generators from the Gen-2004-020 project for Scenario 15. The wind turbines remain on-line and settle to a final speed near their initial speed after the fault was cleared. Turbine speed is the best indicator of stability for induction machines. The Gen-2004-020 wind turbines remained stable as indicated by the final speed.

**FIGURE 16**



The results of the dynamic simulations for the winter case are shown below in Table 5 and discussed in the following paragraphs.

**TABLE 5**

Scenario	Angle		Speed		Relay		Comments
	Initial	Final	Initial	Final	Tripped	Stable	
1	64.9	74.3	0.200	(1.000)	Yes	Yes	Voltage < 0.3
2	64.9	101.0	0.200	(1.000)	Yes	Yes	Voltage < 0.7
3	64.9	94.2	0.200	(1.000)	Yes	Yes	Voltage < 0.3
4	64.9	145.4	0.200	0.200		Yes	
5	64.9	73.6	0.200	(1.000)	Yes	Yes	Voltage < 0.3
6	64.9	118.2	0.200	0.200		Yes	
7	64.9	74.7	0.200	(1.000)	Yes	Yes	Voltage < 0.3
8	64.9	114.9	0.200	0.200		Yes	
9	64.9	-	0.200	-	Yes		Voltage < 0.3
10	64.9	85.7	0.200	(1.000)	Yes	Yes	Voltage < 0.7
11	64.9	-	0.200	-	Yes		Voltage < 0.3
12	64.9	143.0	0.200	0.200		Yes	
13	64.9	-	0.200	-	Yes		Voltage < 0.7
14	64.9	66.0	0.200	0.200		Yes	
15	64.9	-	0.200	-	Yes		Voltage < 0.7
16	64.9	65.6	0.200	0.200		Yes	
17	64.9	-	0.200	-			
18	64.9	65.5	0.200	0.200		Yes	

Table 5 illustrates that the voltage relays tripped the wind turbines in Scenarios 1, 2, 3, 5, 7, 9, 10, 11, 13 and 15. For eight scenarios, the wind turbines rode through the fault and remained on-line. For induction machines, stability is best measured by the speed deviations (i.e., whether the machine continues to accelerate or stalls.) In the scenarios where the wind turbines units remain on-line, they remained stable as indicated by the final speed which settled close to the initial value once the fault was cleared and the transients subsided.

Figure 17 below shows the angle swings of several machines in the area for Scenario 1. Scenario 1 simulated a three-phase fault with three re-closings. The swings for the multiple reclosures can clearly be seen. System stability is maintained as indicated by the damping of the angle swings. The results obtained using the winter basecase are very similar to those obtained using the summer basecase as provided in Figure 11 except where the units selected for plotting differed.

FIGURE 17

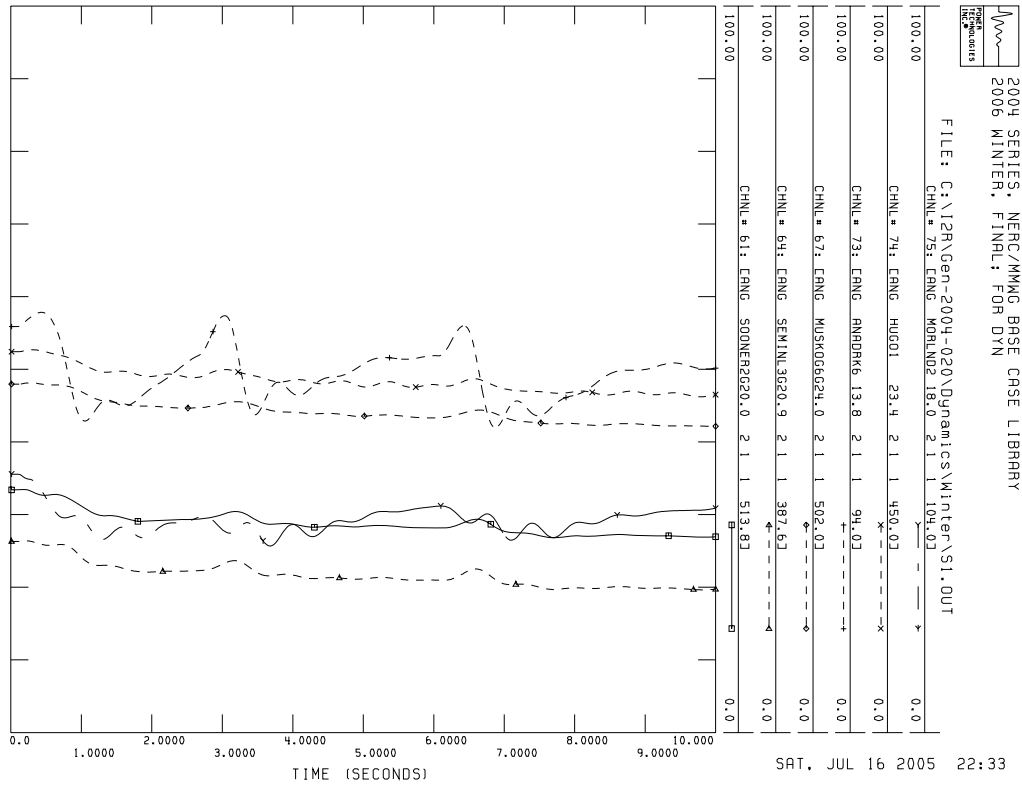

Figure 18 below shows the electrical output from six selected generators from the Gen-2004-020 project for Scenario 1. Figure 18 demonstrates that the generators are tripped off-line as the electrical output goes to zero. The sequence of events for this scenario is as follows:

- Time = 0.100 Fault is applied
- Time = 0.108 Voltage drops below 0.3 and relay timer is set
- Time = 0.129 Breaker time is set after 0.02 second delay
- Time = 0.279 Wind generators are tripped after 0.15 breaker time

The sequence of events is similar for Scenarios 1, 3, 5, 7, 9 and 11. The only difference between the summer and winter cases was that voltage was slightly higher at time 0.108 with the winter basecase.

**FIGURE 18**

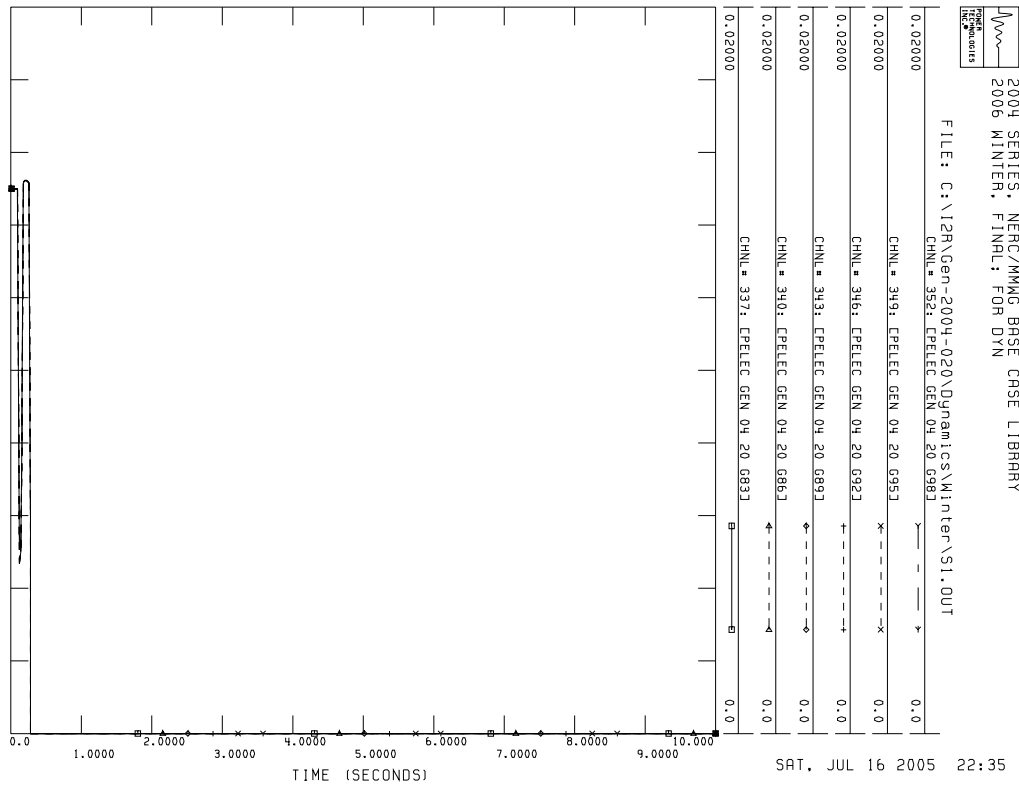

Figure 19 below shows the angle swings of several machines in the area for Scenario 2. Scenario 2 simulated a single-phase fault with three re-closings. The swings for the multiple reclosures can clearly be seen. System stability is maintained as indicated by the damping of the angle swings. The results obtained using the winter basecase are similar to those obtained using the summer basecase as provided in Figure 13 except where the units selected for plotting differed.



**FIGURE 19**

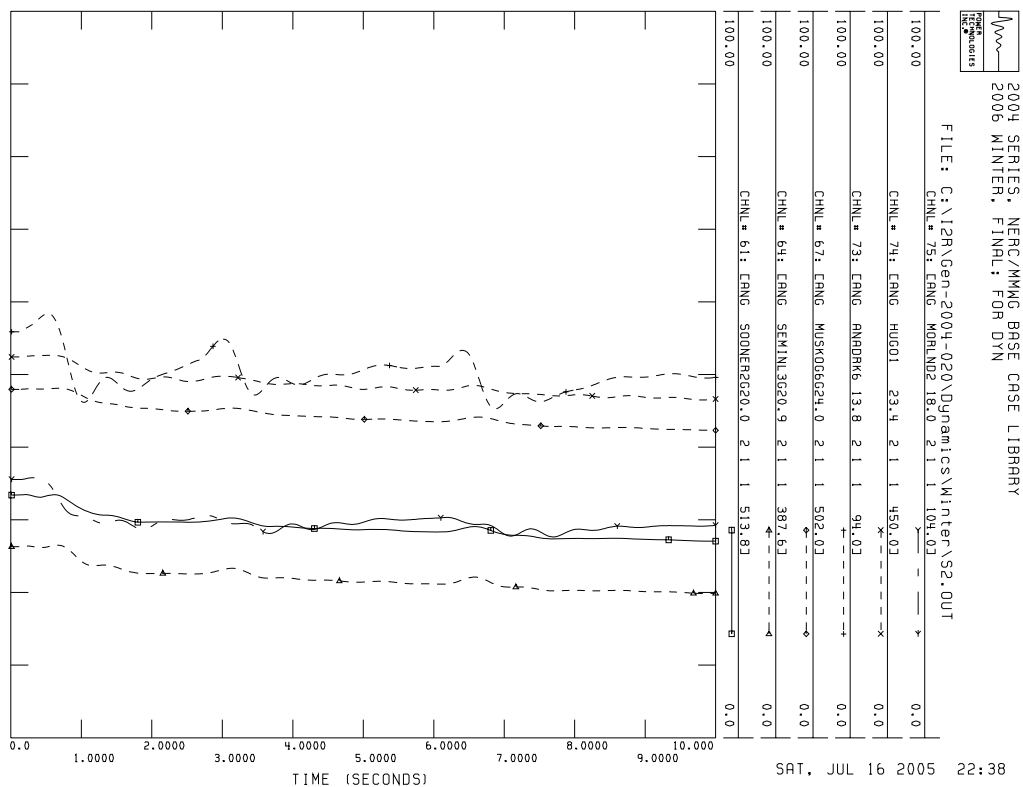

Figure 20 below shows the electrical output from six selected generators from the Gen-2004-020 project for Scenario 2. Figure 20 demonstrates that the generators are tripped off-line as the electrical output goes to zero. The sequence of events for this scenario is as follows:

- Time = 0.100 Fault is applied
- Time = 0.113 Voltage drops below 0.7 and relay timer is set
- Time = 0.133 Voltage rises above 0.7 and relay timer is reset
- Time = 0.158 Fault Removed
- Time = 0.258 Fault is re-applied
- Time = 0.267 Voltage drops below 0.7 and relay timer is set
- Time = 0.367 Breaker time is set after 0.1 second delay
- Time = 0.517 Wind generators are tripped after 0.15 breaker time

The sequence of events is similar for Scenarios 2 and 10. Voltage dropped below the next lowest setting of the voltage relays one time step later using the winter basecase as compared to the summer basecase. Reduction in the fault time to a value below 6 cycles may allow the wind turbines to remain on-line.

**FIGURE 20**

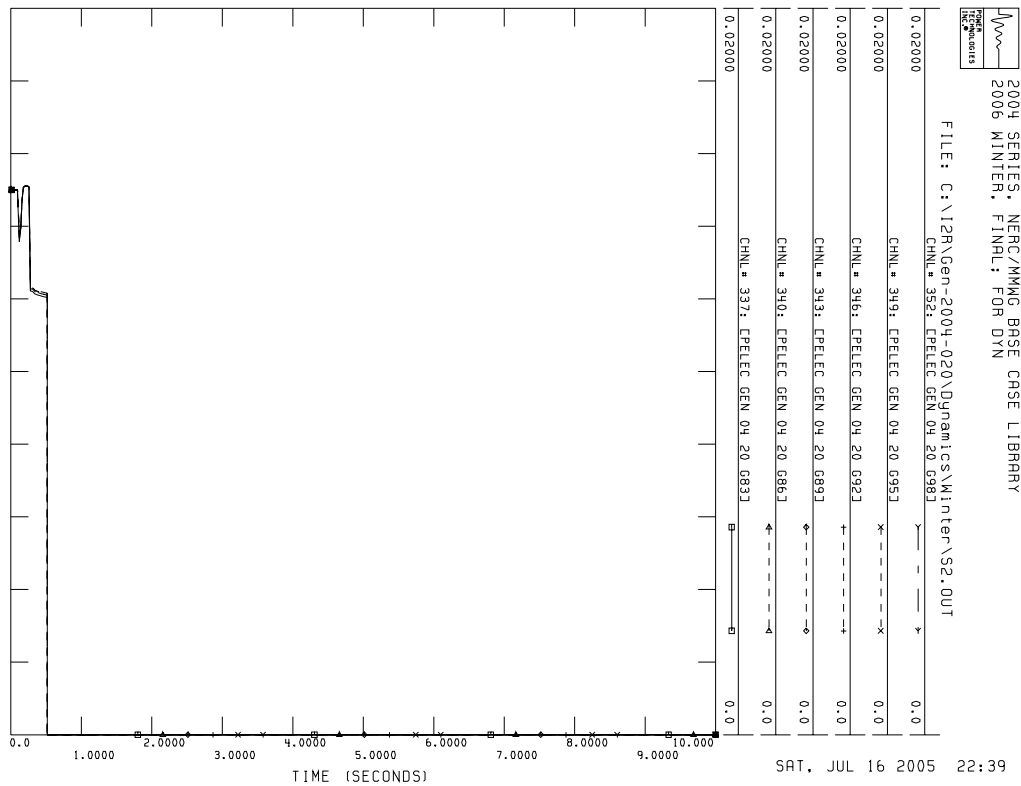

Figure 21 below shows the angle swings of several machines in the area for Scenario 18. Scenario 18 simulated a single-phase fault with two re-closings. The swings for the multiple reclosures can clearly be seen. System stability is maintained as indicated by the damping of the angle swings.

**FIGURE 21**

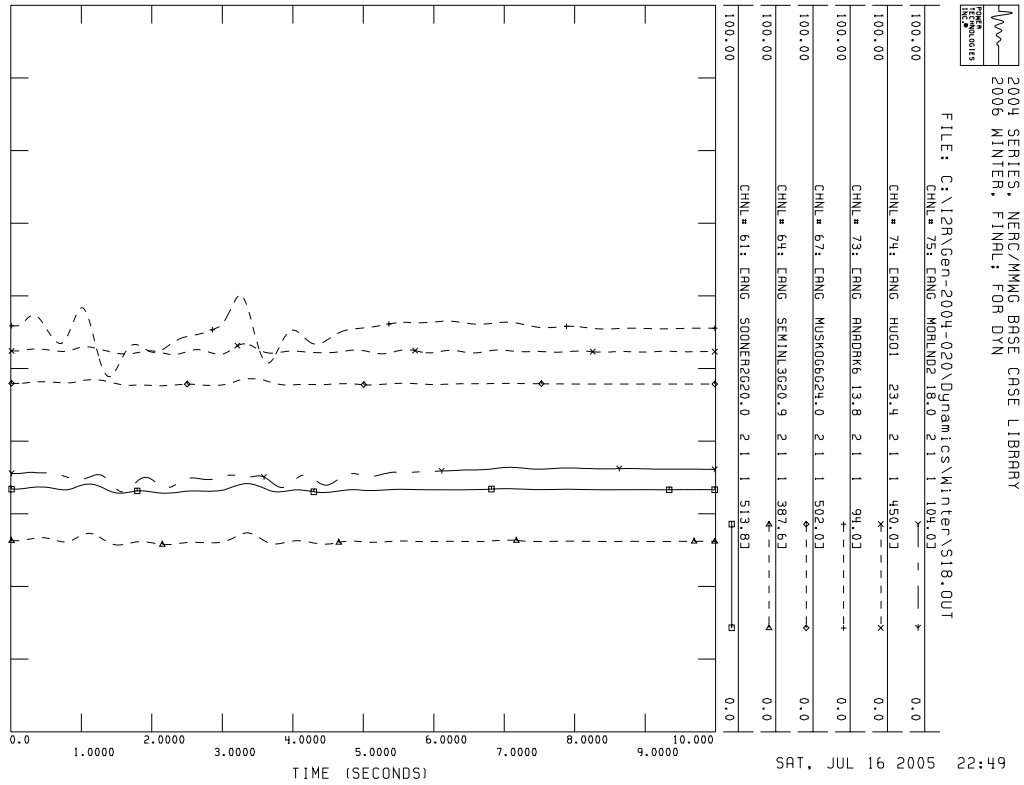
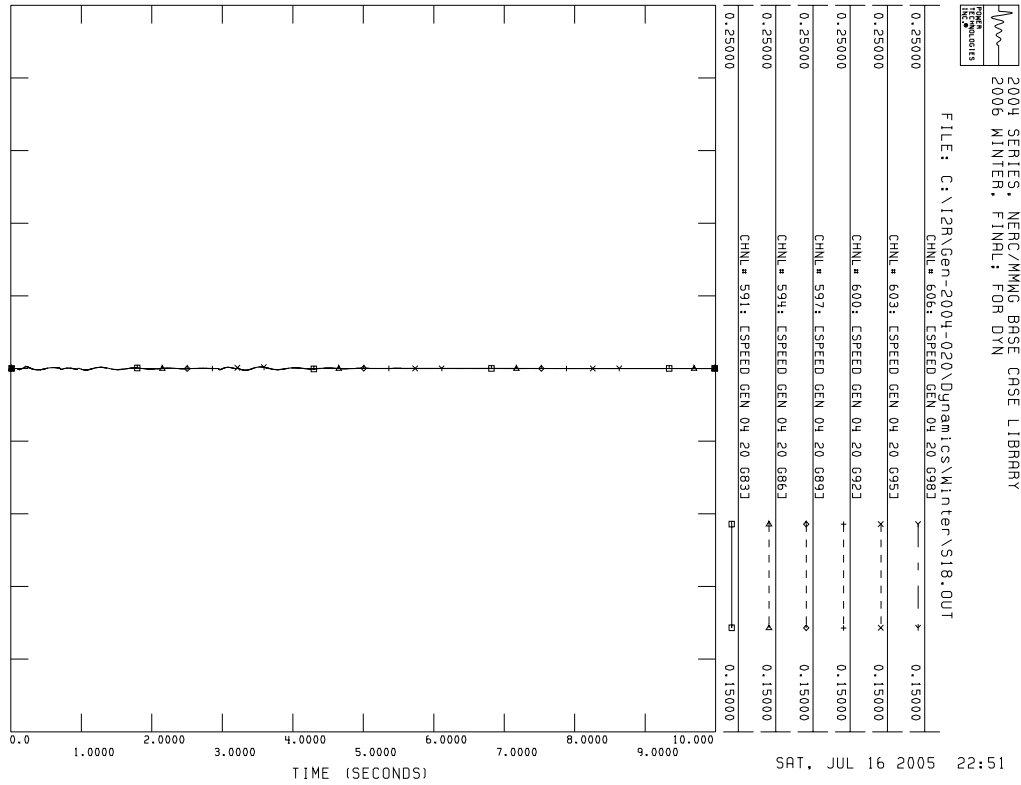

Figure 22 below shows the turbine speed from six selected generators from the Gen-2004-020 project for Scenario 18. The wind turbines remain on-line and settle to a final speed near their initial speed after the fault was cleared. Turbine speed is the best indicator of stability for induction machines. The Gen-2004-020 wind turbines remained stable as indicated by the final speed.

**FIGURE 22**



**VIII. SENSITIVITIES**

It appeared that the wind turbines would remain on-line in several of the scenarios if the fault application time after reclosing were reduced below 6 cycles. Scenarios 2, 10 and 13 were simulated using the summer basecase with a reduced fault application time of 5-5.5 cycles. Figure 23 below shows the angle swings of several machines in the area for modified Scenario 2. Modified Scenario 2 simulated a single-phase fault with three reclosings. The swings for the multiple reclosures can clearly be seen. System stability is maintained as indicated by the damping of the angle swings.

**FIGURE 23**

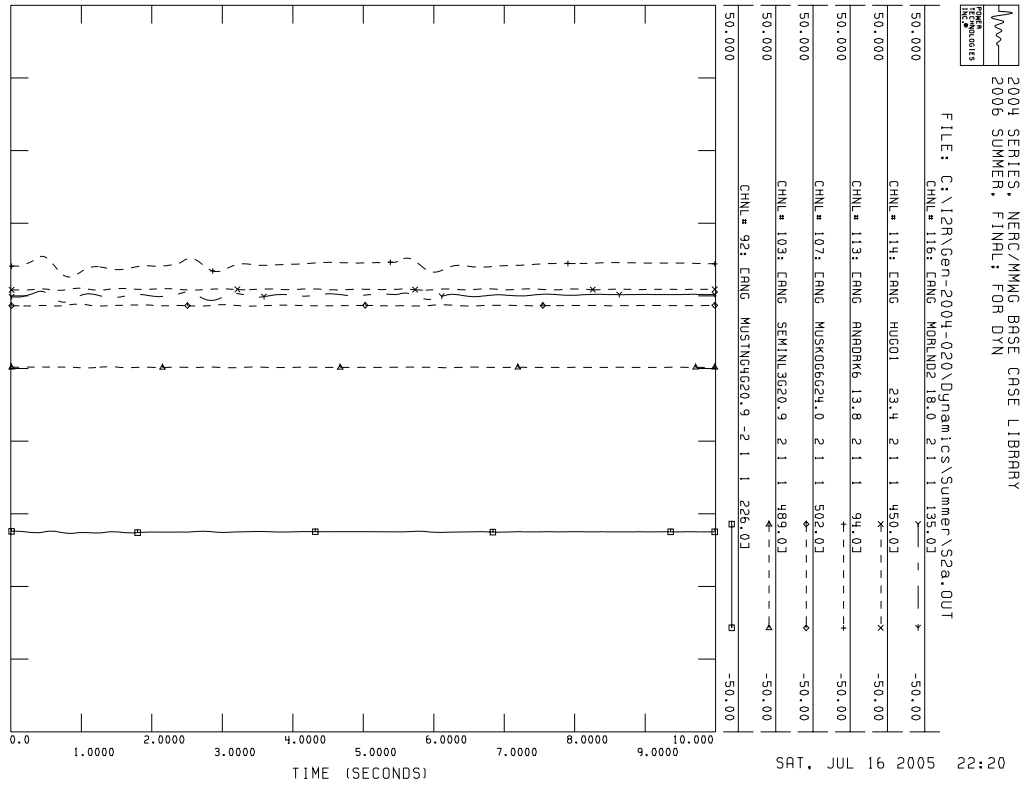
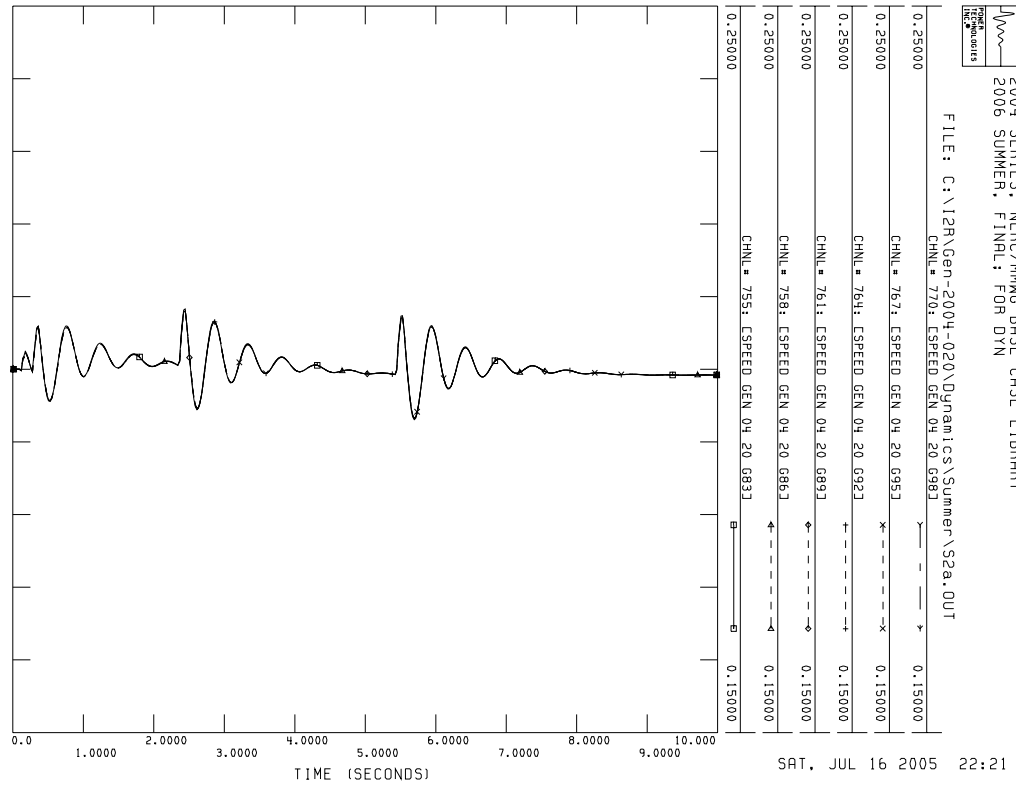

Figure 24 below shows the wind turbine speed from six selected wind generators from the Gen-2004-020 project for modified Scenario 2. Oscillations due to the initial fault application and reclosing can be seen in the plot. The wind turbines remained on-line with the reduced fault application time after reclosing. The wind turbines settle to a final speed near their initial speed after the fault was cleared. The Gen-2004-020 wind turbines remained stable as indicated by the final speed.

**FIGURE 24**



Scenarios 2, 10, 13 and 15 were simulated using the winter basecase with a reduced fault application time of 5-5.5 cycles. Figure 25 below shows the angle swings of several machines in the area for modified Scenario 2. Modified Scenario 2 simulated a single-phase fault with three reclosings. The swings for the multiple reclosures are not as distinct as those for the three-phase faults are still distinguishable. System stability is maintained as indicated by the damping of the angle swings.

**FIGURE 25**

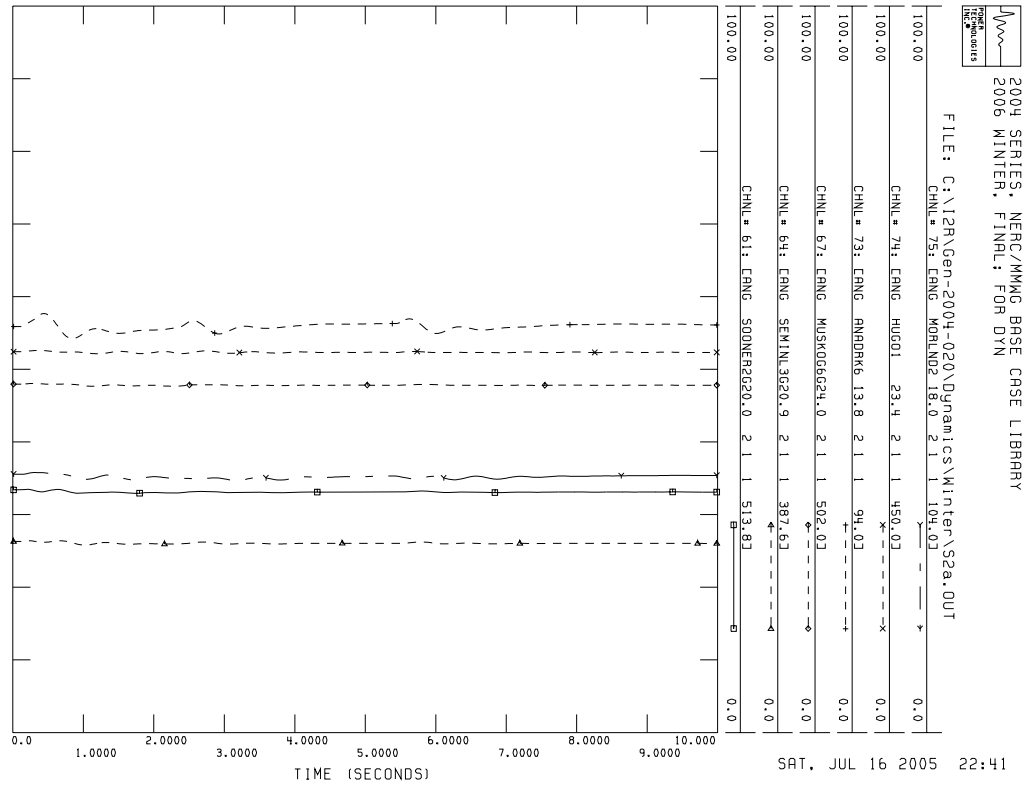
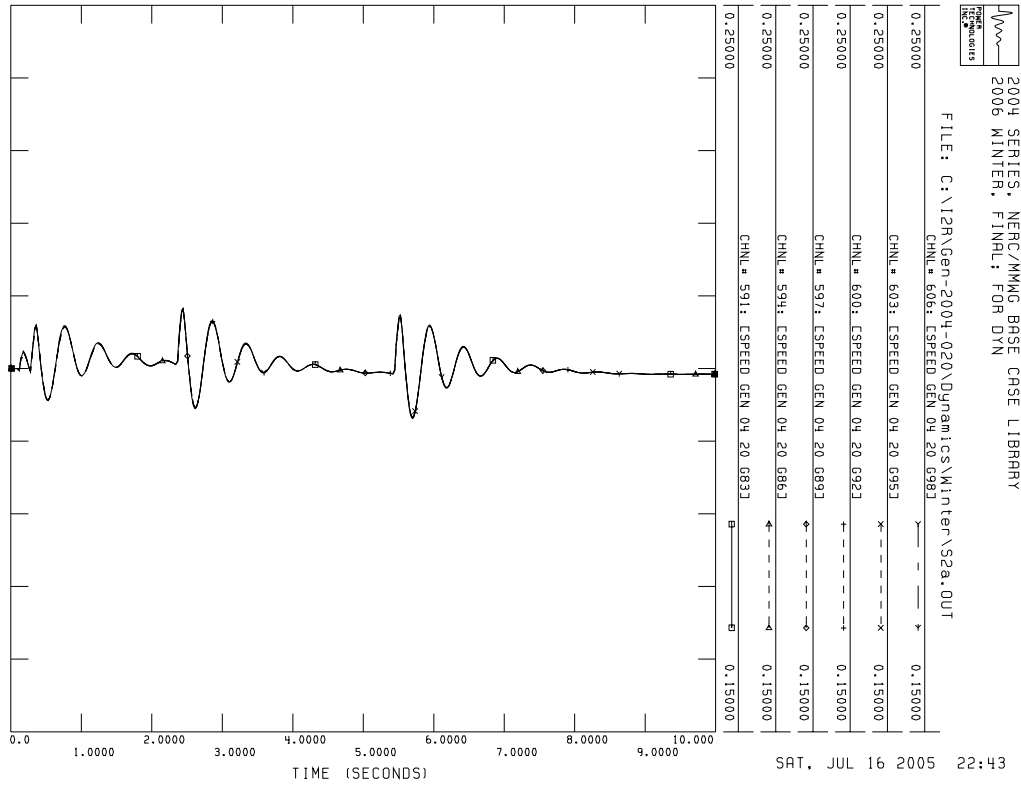

Figure 26 below shows the wind turbine speed from six selected wind generators from the Gen-2004-020 project for modified Scenario 2. Oscillations due to the initial fault application and reclosing can be seen in the plot. The wind turbines remained on-line with the reduced fault application time after reclosing. The wind turbines settle to a final speed near their initial speed after the fault was cleared. The Gen-2004-020 wind turbines remained stable as indicated by the final speed.

**FIGURE 26**



**IX. COST ESTIMATE**

Relaying packages of the GE LVRT turbines may be available that would provide faster fault clearing after reclosing allowing the wind turbines to remain on-line in Scenarios of both the Summer and the Winter cases studied where the units tripped. Based on the high number of trips that occurred for the faults studied the Customer shall investigate the GE LVRT turbine relaying packages to determine if the projects needs these relaying packages.

**X. CONCLUSIONS**

The following conclusions are reached from the load flow and dynamic analysis performed in this study:



- The system remained stable for all eighteen scenarios simulated using the summer model.
- The system remained stable for all eighteen scenarios simulated using the winter model.
- The wind turbines were tripped by the under voltage relays in nine/ten of the eighteen scenarios using the summer/winter basecase for nearby faults including single-phase faults.
- For most of the under voltage tripping the voltage dropped below the lowest acceptable level. The timer for this level is extremely short and thus does not allow for faster relaying.
- For at least three of the fault scenarios, the under voltage tripping occurred after reclosing. Faster reopening after reclosure may allow the relays to be reset and keep the wind turbines on-line. Relaying packages of the GE LVRT turbines may be available that would ride through these faults.

If any previously queued projects that were included in this study are not constructed, then this System Impact Study may have to be revised to determine the impacts of this Interconnection Customer's project on SPS transmission facilities. In accordance with FERC and SPP procedures, the study cost for restudy shall be borne by the Interconnection Customer.